

WARNING: DON'T SMOKE WHILE WORKING ON THE FUEL SYSTEM

1. First, the fuel pressure should be relieved before opening any lines.

From underneath the left side dash near the kick panel, there is a fuse box. To temporarily disable the fuel pump, remove fuse 2.

Start the vehicle and allow the engine to stall. Remove the ignition key and reinstall the fuse.

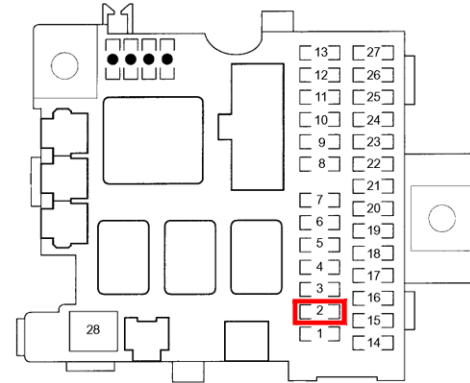

2. CAUTION: Disconnecting the battery may cancel the fault memories of some control units. Consequently, before disconnecting the car's battery, always interrogate the fault memories. Investigate stored faults and, once any faults have been remedied, cancel the fault memory. Also, be sure the radio code is recorded.

Open the hood and unscrew and disconnect the negative terminal of the battery using a 10mm wrench.



3. Using a pair of pliers, release the OEM spring clamp from the PCV valve hose found on the valve cover. Carefully pull the hose off the PCV valve barb.

Using a 10mm socket wrench, remove both M6 acorn nuts that secure the fuel rail dress-up cover, as shown.

Remove and discard the OEM fuel rail dress-up cover.



4. Using a pair of needle nose pliers, squeeze and release the white plastic wiring harness clip fastener (shown).

NOTE: this L-shaped bracket and plastic clip can be reused with the Radium Engineering fuel rail.



5. Use a 22mm wrench to loosen the pulse damper banjo bolt shown. Some fuel may spill out of this connection so have a rag handy.

Using a pair of pliers, slide the spring clamp down the fuel pressure regulator (FPR) return hose. Slide the fuel pressure regulator (FPR) hose off and catch any fuel that may be spill out of this connection with a rag.

Pull the vacuum hose off the FPR nipple.

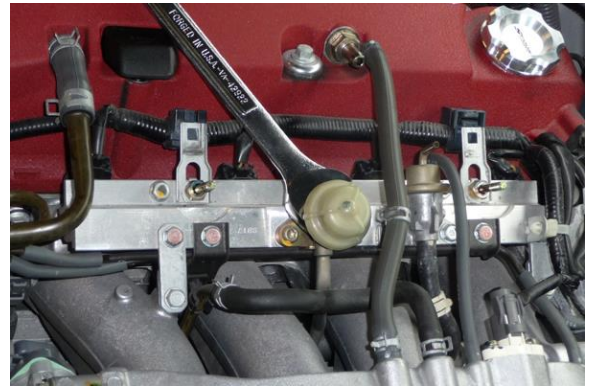

6. Use a 10mm socket wrench to remove both M6 bolts which hold the 2 hard vacuum line brackets.

NOTE: These hard lines that run along the underside of the OEM fuel rail are for the air pump valve system. In later steps, the included vacuum hose will replace these hard lines.

Pull the vacuum hoses off the corresponding components.



7. Using a 10mm socket wrench, remove the four M6 bolts that secure the two mounting brackets that attach the fuel rail to the intake manifold runners. These two brackets will be reused.

Using a 10mm socket wrench, remove the three M6 nuts which secure the fuel rail to the studs that mount to the intake manifold head flange, as shown.



8. Carefully pull the fuel rail out of the vehicle. Have a rag handy as there will be excess fuel still remaining in the fuel rail.

Gather up any of the injector O-rings or grommets that did not come out as one and put them back with their respective fuel injector.

Take this time to clean the injector ports on the intake manifold. Damp cotton swabs can be quite useful for cleaning these tight areas.

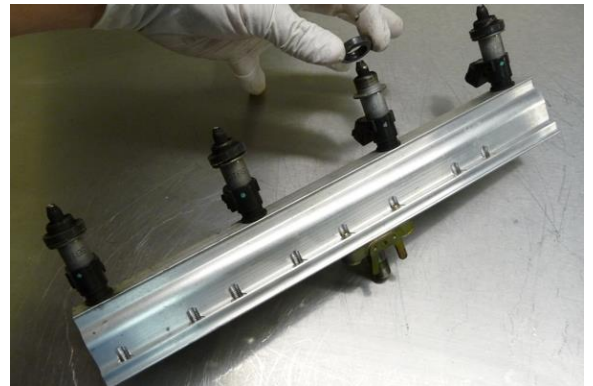

9. Gently pull each fuel injector from the OEM fuel rail. Inspect all O-rings and grommets for rips and tears and replace, if necessary. **Lubricate the O-rings when reinstalling injectors into Radium fuel rail.**

2000-2005 Inlet Top-Side Injector O-Ring: Honda P/N: 91301-PM7-003

2006-2009 Inlet Top-Side Injector O-Ring: Honda P/N: 91301-PLC-000

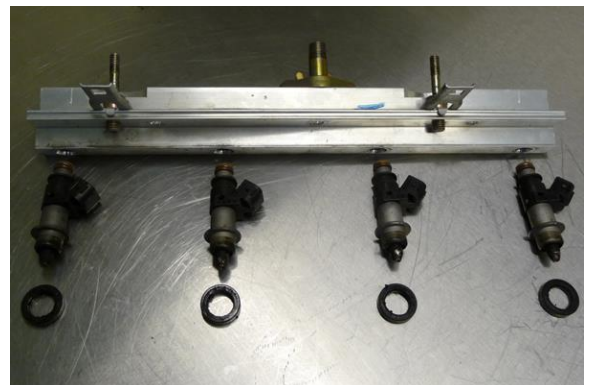

10. For 2004-2005 models, use a T30 Torx wrench to remove and discard both M6 bolts that secure the banjo bolt flange to the OEM fuel rail. To release, pull the banjo bolt flange away from the fuel rail.

If the OEM banjo feed hose will be reused for 2000-2003 models, Honda P/N: 16623-PCX-003 (shown) must be purchased.

Also, new crush washers should be purchased if reusing the OEM banjo hose. Honda P/N: 16705-PD1-003 and 90428-PD6-003



11. If the OEM banjo will NOT be reused, install the included block-off-plate, O-ring, and 4 button head screws, as shown. Lubricate the O-ring with clean engine oil.

If the OEM feed hose WILL be reused, install the banjo bolt flange to the Radium fuel rail using the 2 (out of the 4) included screws.

Install the FPR (shown) to the Radium fuel rail using the OEM hex head bolts. Inspect the O-ring for damage or tears. Replace if necessary. The FPR screen from the OEM rail will not be reused.

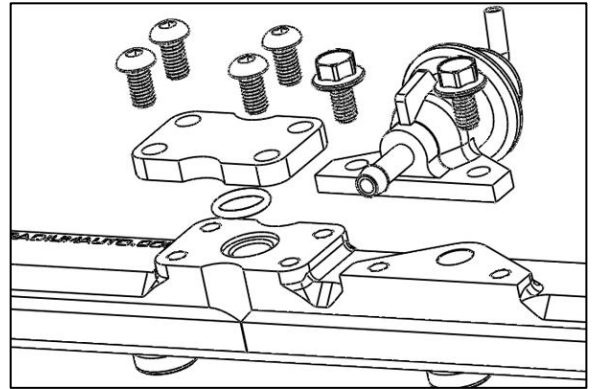

12. When mounted, the rear of the fuel rail will come close to contact with the OEM air control valve (notch if necessary). Install an 8AN ORB "port" plug fitting (such as Radium P/N: 14-0150) to the rear port if the OEM air control valve will remain in the vehicle.

NOTE: if the OEM air control valve is removed and the rear port is to be used, a 8AN ORB (3/4"-16 threaded) "port" fitting (not included) MUST be used. "Port" fittings don't have the long 37 degree flare on the O-ring side and thus will NOT impede injector #4 flow.

To prevent failure, all O-rings MUST be lubricated prior to assembly.



13. If 20-0091-01 or 20-0091-PK was purchased, install the included -6AN adapter fitting to the top port. In later steps, the PTFE feed hose will attach to the fuel rail at this fitting, as shown.

If the OEM banjo hose will be reused, install a port plug (such as Radium P/N: 14-0150) to the front end of the fuel rail.

Alternatively, the 20-0075 Radium Fuel Pressure Gauge and Adapter can be used on the front port. To install, first insert the Radium adapter fitting to the fuel rail. Next, apply Teflon paste to the gauge's 1/8" NPT tapered threads and tighten.

To prevent failure, all O-rings MUST be lubricated prior to assembly.



14. Find the supplied 5/32" vacuum hose. Cut in 2 sections to replace the discarded hard tubes. If rerouting is unclear, use the schematic shown for help.

NOTE: along with protecting the engine from unwanted oil sludge, the Radium S2000 catch can kits also include everything required to eliminate and bypass the awkward OEM hard metal tube loom where these 2 vacuum hoses connect.

Reinstall the fuel rail and components in reverse order. If 20-0091-01 and 20-0091-PK was not purchased, please skip to Step 19.

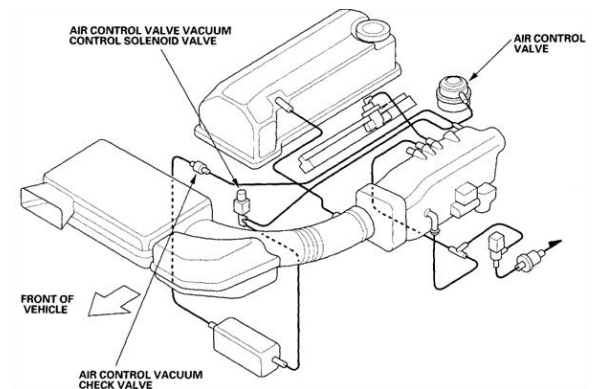

15. If 20-0091-01 or 20-0091-PK was purchased, raise the car and put it on jack stands.

From underneath the vehicle, on the left side there will junction point of where the OEM feed hard line meets up to the soft rubber feed hose (pictured).

Using a 14mm flare nut wrench, unscrew the male inverted flare fitting from the soft rubber hose, as shown. Be careful not to round the hex nut. Have a bucket and rag handy as quite a bit of fuel will drain from this open connection.



16. Using a 10mm socket wrench and extension, remove the two M6 bolts that secure the fuel feed line clamp to the chassis, as shown. These will not be reused.



17. Remove and discard the Honda OEM soft rubber hose (shown) from the vehicle.

Note: If the engine is planned for high horsepower capabilities, the elimination of this banjo assembly restriction from the OEM fuel system is crucial in allowing more fuel flow.



18. Find the female inverted flare to -6AN male adapter fitting in the kit. Screw and secure it to the Radium PTFE hose.



19. From underneath the vehicle, mate the inverted flare fittings. Route the PTFE hose upwards staying clear of hot and/or moving parts. Secure to the -6AN male fitting on the top port of the fuel rail.

After everything is reinstalled, cycle the keyed ignition switch ON/OFF a few times (without starting the engine). This allows the fuel pump to prime the system. CHECK FOR LEAKS! If none are found, start the engine and check again while the engine is running.

INSTALLATION COMPLETE

