

INSTALLATION INSTRUCTIONS

INJECTOR SEATS FOR TOP FEED CONVERSIONS

NISSAN SUBARU TOYOTA MAZDA ENGINES

Customer Support: info@radiumauto.com

Document# 19-0093

WARNING: DO NOT EXPOSE WORK AREA TO ANY SPARKS OR FIRE. DO NOT SMOKE WHILE OPERATING ON THE FUEL SYSTEM. CLEAN UP ALL FUEL SPILLS IMMEDIATELY. WORK IN A WELL VENTILATED AREA.

1. After engine has cooled, thoroughly clean out any dirt or debris found in the intake manifold injector seat bores.

Lubricate the Radium injector seat O-rings AND the intake manifold injector ports with light oil. Press the Radium injector seats down firmly into the intake manifold injector ports until fully seated. If necessary, use a small rubber mallet.

After installing the fuel rail(s), verify fitment. First, push the injectors downward until they bottom out in their respective seat. Now confirm each injectors' upper O-ring is still inserted into the fuel rail bores. Do not pressurize the fuel system until the proper height is achieved.

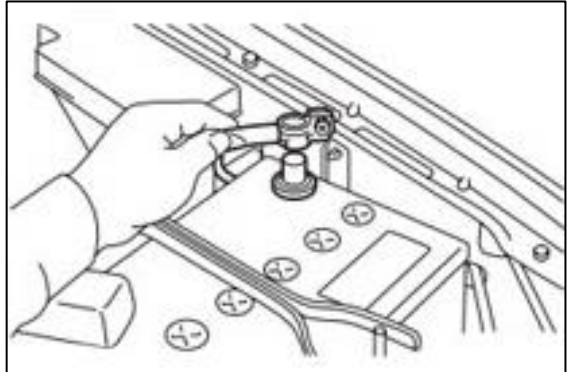

2. Radium Engineering injector seats for Nissan (30mm size).



3. Radium Engineering injector seats for Nissan (25mm size).



4. Radium Engineering injector seats for Subaru (22mm).



4. Radium Engineering injector seats for Toyota.



5. Radium Engineering injector seats shown for Mazda primary rail.



5. Radium Engineering injector seats shown for Mazda secondary rail.

