

# INSTALLATION INSTRUCTIONS

## FUEL PUMP HANGER

MITSUBISHI LANCER EVOLUTION X

Support: [info@radiumauto.com](mailto:info@radiumauto.com)

Document# 19-0116

**WARNING: DO NOT EXPOSE WORK AREA TO ANY SPARKS OR FIRE. DO NOT SMOKE WHILE WORKING ON THE FUEL SYSTEM. CLEAN UP ALL FUEL SPILLS IMMEDIATELY. WORK IN A WELL VENTILATED AREA.**

1. **Note:** It is highly recommended this install be done with no fuel in the tank to reduce fuel spills and make installation easier and safer. Draining the tank is recommended.

Remove the rear bench seat. Find the fuel pump access panel on the left hand side under the lower seat cushion. To remove, first disconnect the electrical loom clip (shown) then carefully pull upwards around the perimeter of the panel. It is fastened down with an adhesive caulking, but can be removed and reinstalled easily.

To depressurize the fuel system, first squeeze the tab and unplug the gray wiring connector on top of the pump housing (shown). Start the engine and allow it to stall. Remove the key from the ignition. Unscrew the gas tank filler cap temporarily to relieve any residual pressure.



2. Dislodge the battery panel in the trunk and disconnect the negative terminal of the battery with a 10mm socket wrench. CAUTION: Disconnecting the battery may cancel fault memories of some control units. Consequently, before disconnecting the car's battery, always interrogate the fault memories.

As shown, it is recommended to clean the top of the fuel pump housing and the surrounding area. This will prevent loose dirt from falling into the gas tank.

To detach the pressure feed line, use a flat head screwdriver to dislodge the green plastic retaining clip upwards. Next, simply pull the connector away from the fitting. Use a rag to clean up any spilled fuel. Loosen the hose clamp on the return hose and remove it from the housing's barb fitting, as shown.



3. To release the OEM fuel pressure sensor, spread the two retaining tabs outwards and simultaneously pull upwards, as shown. Unplugging this connector is not necessary.

To allow extra room, the nearby rubber grommet can be removed and the OEM wiring harness can be pulled out for easier modification access later.

Using an 8mm wrench, loosen the six M5 nuts holding the retaining ring. Next, hold the fuel pump housing down with one hand and remove each nut one by one by hand as the housing is slightly spring-loaded.

Finally, remove the black steel retaining ring and set aside as it will be reused.



4. Before removing the OEM fuel pump housing, place an empty bucket nearby, there will be residual fuel in the gas tank. Tilt the fuel pump housing towards the right side of the vehicle then pull up. Be careful not to damage the fuel level float arm. Using pliers, release the crossover hose, as shown. Pull the OEM fuel pump housing out and drain into the bucket.

Remove the large rubber gasket from the OEM fuel pump housing.

Clean the fuel pump housing and set it onto a workbench. There will be fuel in the OEM bucket. The only two parts that will be reused are the fuel level sender and temperature sensor.



5. To remove the fuel level and fuel temperature sensors from the OEM fuel pump housing, first depress the thumb tab and unplug the 3-pin connector from underneath the top plate. Next, pry and pop the fuel temperature sensor probe out of the securing tabs.

To remove the fuel level sender, press the upper right thumb tab inwards and simultaneously push the module up and out gently until it unlocks. Be careful not to damage the circuit board or bend the float arm. Finally, release the temperature probe wires from the fuel pump housing tabs to fully release the sensor assembly.

**If the fuel pump hanger kit was purchased with pump(s) included, skip Steps 6-9.**

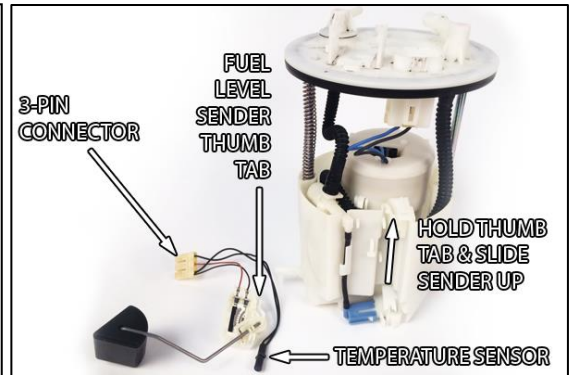

6. **If this kit was shipped from Radium after 9/1/18, this step does not apply and should be skipped. A service-free venturi jet pump was implemented that features a pressure relief valve.**

If this kit was shipped from Radium prior to 9/1/18, there will be 2 different venturi jet pump orifices included. The preinstalled "green" orifice is typically best for single pump applications. The "gold" orifice is typically best for dual pump applications. The proper orifice will be determined by return line backpressure. This is dictated by many factors including: flow rate of pump(s), staged pumps, engine fuel consumption, diameter and length of return hose, etc.

The venturi jet pump O-rings MUST be lubricated prior to assembly. If installing fuel pumps, the jet pump hose assembly can stay intact unless the orifice needs to be swapped.

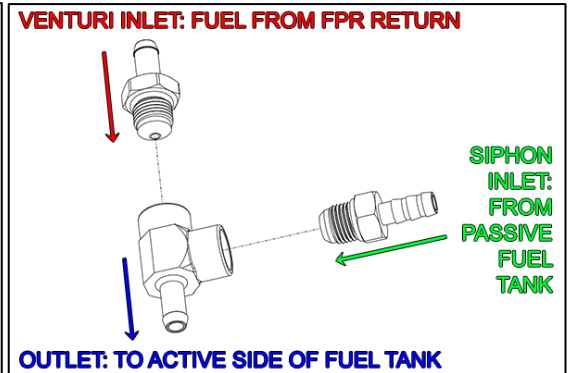

7. To install pumps, the hanger must be partially disassembled. First, remove the 3 internal pump hanger bracket bolts using a 4mm Allen wrench. and replace with the included barb fitting (lubricate O-ring first). Note: The barb fittings (pictured in red) can be used in either port since they share the same outlet.



8. Rotate and align the fuel pump(s) concentrically with the cut-outs in the internal pump bracket, as shown in red. Tighten the EFI hose clamps after the alignment is complete. Reinstall the green internal pump bracket. Using the included zip tie, strap the jet pump body to the green bracket. Next, press the filter sock(s) onto each pump inlet and secure with the star washer.

NOTE: The Radium Fuel Pump Hanger was designed for a specific type of fuel pump sock filter. Large filter socks which have a rigid internal "skeleton" insert can be difficult since they cannot be formed inside the collector box. See below for filter socks that are recommended:

- RADIUM Engineering, P/N: 14-0143 Filter Sock
- AEM, P/N: 50-1000 (the filter sock that is provided in this fuel pump kit)
- AEM, P/N: 50-1200 (the filter sock that is provided in this fuel pump kit)

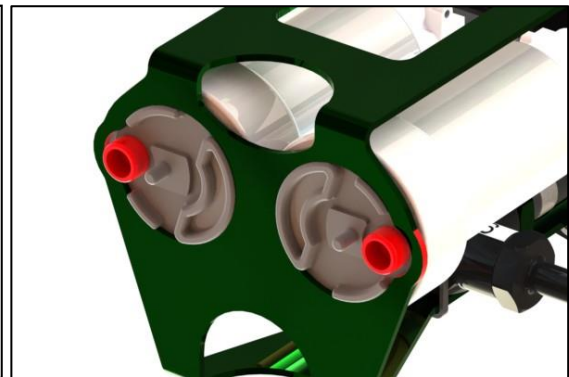

9. Remove the Radium fuel sensor mount attached to the collector box (shown in red). Slide the 2 included zip ties (shown in yellow) in and out of the 4 slotted holes. Using a 3mm Allen wrench, reattach the Radium fuel sensor mount to the collector box using the provided screws.

**-For fuel hangers purchased before Feb 2018, use the red mount lower holes, as pictured.**  
**-For fuel hangers purchased after Feb 2018, use the red mount center holes. This was changed to prevent fuel temp sensor wire interference with the M5 button head bolt. As long as these are installed according to the purchase date, the fuel level float is kept at the proper height.**

Next, carefully slide the OEM fuel level sensor downwards onto the mount until the tab locks into place. As depicted, secure the OEM fuel temperature probe to the zip ties and cut the tails.

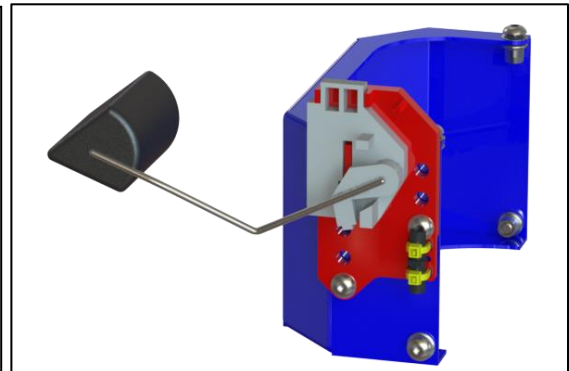

10. **Internal Wiring:** Find the hanging internal fuel pump connections from the underside of the conductive studs.

**If purchased without preinstalled fuel pumps:**

For single fuel pump applications, use the preinstalled connector with black/red wires to power Pump #1. Included loose in the kit is a second connector with gray/orange wires for a second fuel pump. Connect the orange wire to the stud labeled "PWR Pump 2" and the gray wire to the stud labeled "GND Pump 2". Use the included locking nuts to secure the ring terminals to the studs. Connect the second connector to the second pump.



11. Locate the fuel level sender and temperature sensor which should be attached to the collector box, cut the 4 wires at the white OEM 3-pin connector allowing as much slack as possible. Strip all wires. Next, crimp the 4 included terminals to each wire using a tool such as Molex 63811-1000 hand crimper. Slide the terminals into the plastic plugs until a "click" is heard. Polarity is not critical.

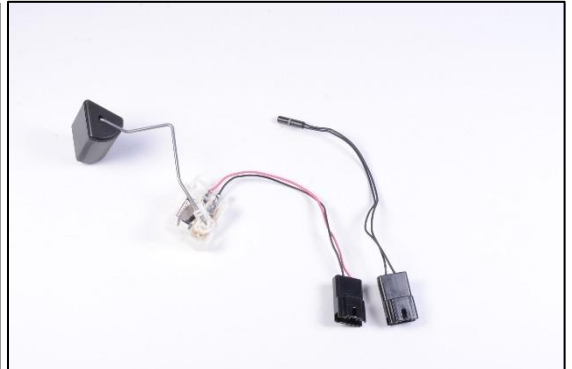

12. Reach in the gas tank and find the short rubber crossover hose. It attaches to a hard tube towards the left rear of the vehicle with a spring clamp.

Loosen the clamp and rotate the rubber crossover hose so that the end points toward the right side of the vehicle, as shown. This can typically be done by hand but pliers can be used if necessary.



13. Be sure the ball check valves are installed into the collector box pieces with the green fitting on the outside. Unscrew the four M5 button head bolts in the rivet nuts and set aside.

Insert both sections of the 2-piece collector box into the gas tank disassembled. **Note: The collector box will not fit through the tank opening if assembled.**

To assemble the collector box, rotate the 2 pieces around inside the gas tank to easily access the 4 connection areas. Using a 3mm Allen wrench, loosely secure the provided M5 bolts through the one piece and into the rivet nuts of the other piece. Once all 4 bolts have been started, tighten them down.



14. Observe the orientation of the collector box in the picture at right.

The fuel level sender should face towards the rear of the vehicle and the collector box's large half circles should be concentric with the tank's circular bottom plate.

This is the orientation that the collector box should be sitting just before the fuel pump hanger assembly is lowered into the gas tank.

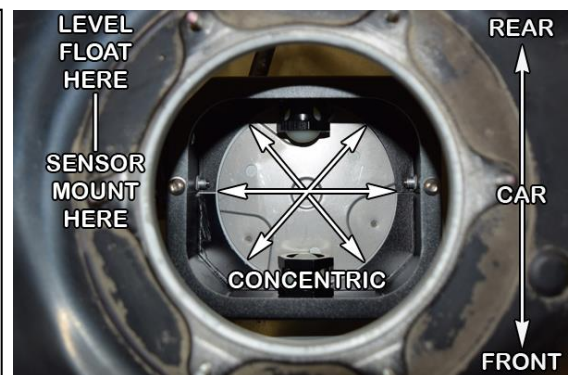

15. Install and fully seat the OEM rubber gasket underneath the fuel pump hanger top plate, as shown.

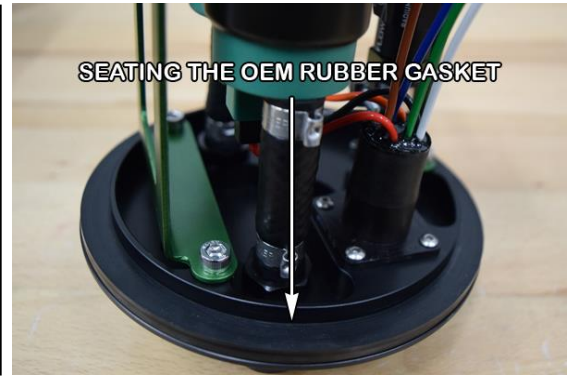

16. Lower the fuel pump hanger assembly close to the gas tank hole. From the collector box, bring the 2 connectors for the fuel level and temp sensor up and out of the tank. Assemble the 2 included mating connectors so the wires attach as follows. Position the wire slack so the wires will sit towards the front of the gas tank when lowered down.

Connect the temperature sensor plug to the mating plug on the hanger with the green/white wires. Connect the level sender to the mating plug with the blue/brown wires.

**Lubricate the jet pump barb with light oil.** Reach in to pull the crossover hose out and slide it over the jet pump barb. Secure the OEM spring clamp using pliers, as shown.

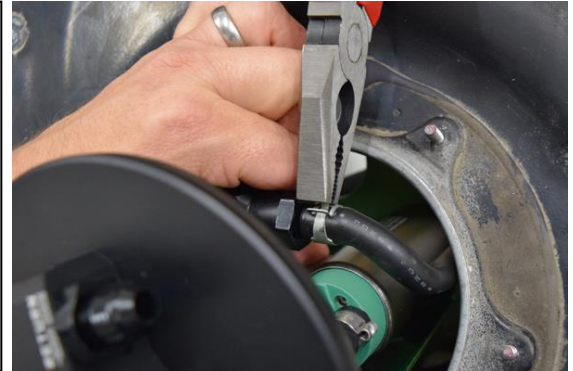

17. Wrap the OEM retaining ring around the hanger top and then carefully drop the hanger down onto the tank. It may be necessary to remove the "Pump Out" fitting to install the retaining ring.

Make note of the orientation graphic on the top plate of the pump hanger assembly and make sure it is aligned correctly with the vehicle, as shown.

Reinstall the OEM M5 flange nuts using an 8mm wrench. Tighten to factory specs in steps using an alternating crisscross pattern.



18. The top plate and gasket should be flush with the mounting ring.

When the fuel pump hanger is fully seated into the collector box, it would look like the example in this picture.

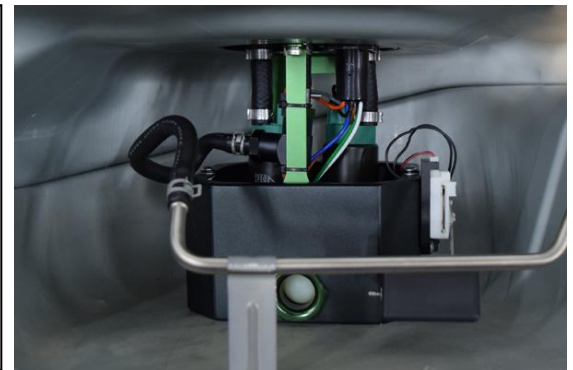

19. Lubricate the O-ring found on the OEM pressure sensor and insert it into the top of the hanger.

Install the included black hold down bracket and lineup the 2 holes. Using the included button head bolts, secure the pressure sensor down as shown with a 2.5mm Allen hex wrench.



20. **External Wiring:** Cut off the OEM 5-pin fuel pump control module connector, as shown. Remove some of the tape, and wire loom than strip the insulation on all 5 wires about ¼" back.

<b>Fuel Level Sender, Thin AWG:</b>	2008-2010 = Yellow/Red	2011-2016 = Red
<b>Fuel Temp Sensor, Thin AWG:</b>	2008-2010 = White/Black	2011-2016 = Purple
<b>Sensor Ground, Thin AWG:</b>	2008-2010 = Black	2011-2016 = White/Black
<b>Pump Power, Thick AWG:</b>	2008-2010 = Blue	2011-2016 = Blue
<b>Pump Ground, Thick AWG:</b>	2008-2010 = Black	2011-2016 = Black

Cut three ½" pieces of the small diameter shrink tube and insert a piece onto each sensor wire (three small gauge wires). Next, crimp a small AWG ring terminal to each wire. Slide the shrink tube over the crimped section of the ring terminal and shrink into place using a heat gun.



21. Use the large diameter shrink tube and large AWG ring terminals to connect the pump wires ("PWR" for positive and "GND" for negative). Single pump applications use the "Pump 1" terminals. After the ring terminals are positioned on the studs, install the plastic nuts. Then tighten the plastic nuts with a 3/8" driver. Be careful not to over-tighten.

NOTE: OEM wiring SHOULD NOT be used with aftermarket pumps which draw more than 15A of current. It is recommended to use the OEM wiring to trigger a fused relay power source for the pump(s) for high current pumps. The PWM square wave will successfully trigger a relay.

Next, connect the black sensor wire to the "Sensor Ground" terminal. Connect the yellow/red wire to "Level +" and the white/black wire to "Temp +". Install the acorn nuts.



22. **Optional high-current wiring**

For high flow aftermarket fuel pumps, consider using Radium DIY wiring kit 17-0031 (shown) for each pump. This includes a dedicated fuse, relay, 10AWG wire, etc.

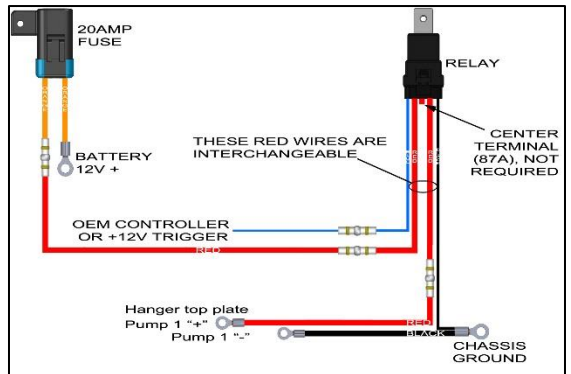

23. **Single Fuel Pump Applications ONLY:**

In some cases, the Mitsubishi fuel pump controller (designed for less than 15A) will be sufficient unless fuel pressure is excessive. To reuse the OEM fuel pump controller and keep the fuel pump duty-cycled, connect the blue wire to the "Pump 1 PWR" terminal and the black wire to the "Pump 1 GND" terminal.

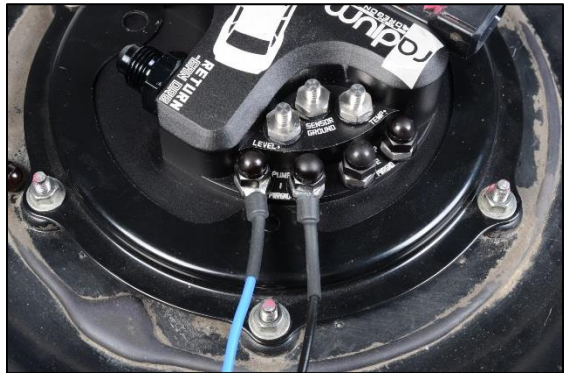

24. **SKIP TO STEP 36 IF THE OPTIONAL PLUMBING KITS WERE NOT PURCHASED.**

**Optional 20-0246-XX Fuel Hanger Feed Kit. Steps 24-33**

Safely raise the vehicle.

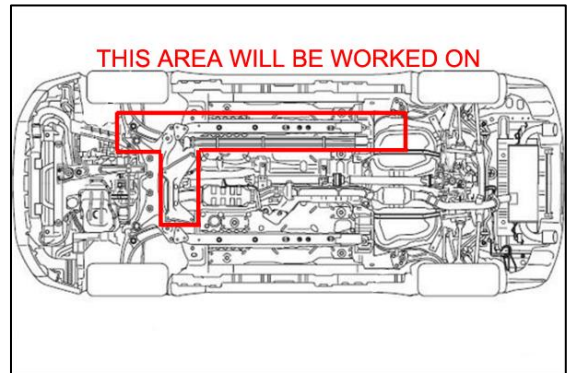

25. The plastic shield (pictured) near the left rear tire and the metal shield near the front left tire that covers the hard lines need to be removed temporarily. Using a 10mm socket wrench, remove the M6 screws and drop the shield down.

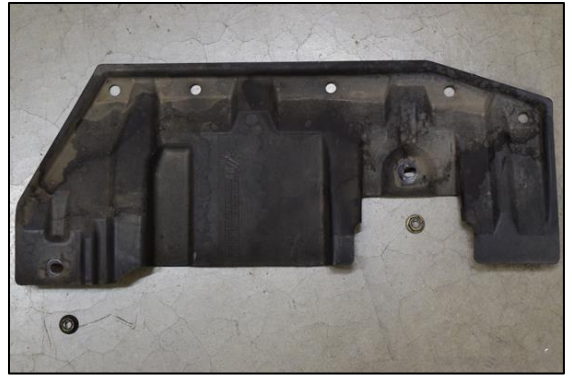

26. The center metal under tray brace (pictured) under the exhaust downpipe elbow and driveshaft needs to be removed temporarily. Remove the 4 bolts and drop the brace down.

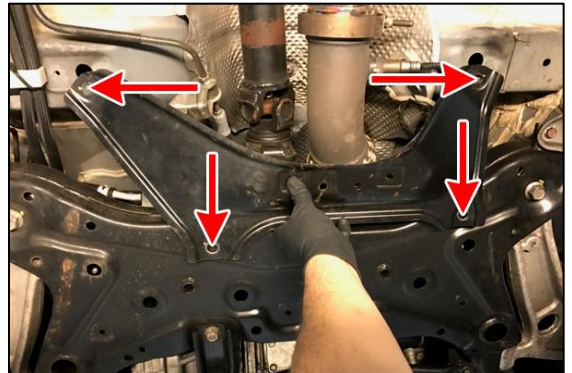

27. When installing the included fuel filter bracket (shown in purple), note that the front OEM hard line shield will be reinstated at the same time. The OEM shield will sit on top of the bracket on one side and underneath the bracket on the other side, as shown.

Use the included stainless steel hardware to secure the shield and bracket. The two M6 bolts require a 4mm Allen wrench.

NOTE:  
Only install the M8 bolt now if the under tray brace will not be reused.

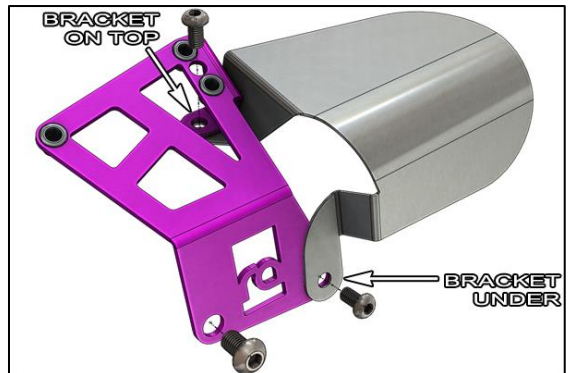

28. Find the fuel filter clamp in the kit.

Using the included stainless steel hardware, install the lower portion of the clamp (shown in red) to the bracket's rivet nuts.

The three M5 bolts require a 4mm Allen wrench.

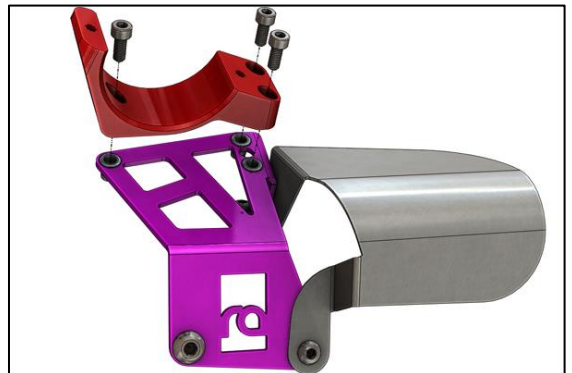

29. Lubricate the O-rings and install the two 8AN adapter fittings into the fuel filter ends.

Temporarily install the filter and upper clamp to the bracket using the three stainless steel hardware.

**Make sure the filter is orientated so the outlet (denoted in green) is pointing towards the engine.**

The two M5 bolts require a 4mm Allen wrench. Do not torque these bolts yet.



30. Find the shorter PTFE hose included in the kit. Route the hose in the engine bay between the fuel filter and the fuel rail keeping the 45 degree hose end at the fuel rail side.

From underneath the vehicle, pull and slide the fuel filter downwards out of the clamp. Torque the straight hose end to the green fuel filter outlet. Slide the fuel filter all the way back into place. Lineup the clamp to the filter, as shown. Have another person simultaneously torque the 45 degree hose end to the aftermarket fuel rail's 8AN male inlet fitting. For hose end clocking purposes, allow the filter to rotate inside the clamp until the 45 degree hose end is tight.

Next, torque the two fuel filter clamp bolts.



31. Loosely install the longer PTFE fuel hose included in this kit from the fuel pump hanger to the fuel filter.

The straight hose end connects to the "PUMP OUT" port.

The 45 degree hose end connects to the fuel filter inlet port. Be sure to route the PTFE hose above the hard brake line, as shown.

Make sure the fuel filter inlet hose end port has sufficient ground clearance, as shown.

Use the included zip ties to secure the PTFE hose to the hard lines underneath the vehicle.

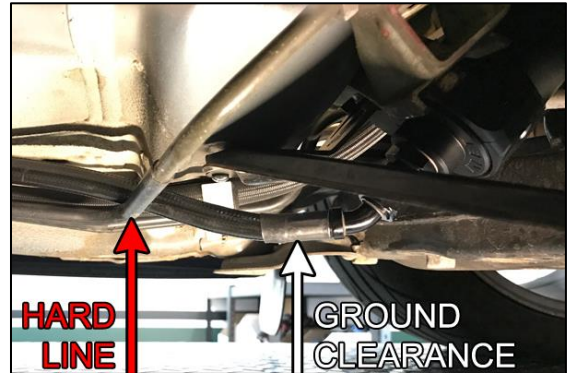

32. Using a 7/8" wrench, torque the 45 degree hose end on the fuel filter inlet first, then torque the straight hose end on the pump hanger. To avoid breaking anything, brace the part. To prevent hose end marring, an aluminum wrench is recommended.

Reinstall the rear plastic hard line shield.



33. When reinstalling the center under tray brace, first check for clearance near the 45 degree hose end. Grind if necessary.

The OEM under tray brace will sandwich the Radium fuel filter bracket. Three of the OEM under tray brace bolts will be reused. For the fuel filter area, use the longer stainless steel button head bolt (shown) included in the kit. Torque with a 5mm Allen hex wrench.



34. **Optional 20-0249 Fuel Hanger Return Kit. Steps 34-35**

This kit will use the OEM feed line as the new return line.

Remove the 6AN ORB fitting from the "RETURN" port on the Radium pump hanger. Transfer the O-ring from this fitting to the included 3/8" SAE Male Fitting. Lubricate the O-ring and install it into the "RETURN" port.

Fully insert the plastic OEM feed line on the green 3/8" SAE male fitting. NOTE: It is always a good idea to use light oil to lubricate the internal O-ring. Push the OEM green lock down to secure the connection. Gently tug the hose connection to verify a positive lock has been made.

**Flush out the fuel remaining in the OEM return as this line will no longer be used.**



35. Torque the 5/16" SAE Male Fitting into either end of the PTFE hose included in the kit. If installing to a Radium fuel rail with a DMR installed onto the top port, make sure the 6AN male return fitting is pointing towards the left side of the vehicle. Loosely install the opposing hose end to the DMR's 6AN male fitting. NOTE: Hose routing will differ if installing onto a different brand pressure regulator.

Install the 5/16" SAE Male Fitting into the OEM "feed" hose (now converted to a return hose). NOTE: It is always a good idea to use light oil to lubricate the internal O-ring. Push the OEM red lock down to secure the connection. Gently tug the hose connection to verify a positive lock has been made.

Wrap the included cushion clamp around the PTFE hose. Using one of the M6 bolts included in the fuel rail, secure the hose to the fuel rail, as shown. Torque the hose end with a 9/16" wrench.



36. **NOTE: This kit eliminates the OEM hanger's "post" fuel pump filter so a low micron aftermarket filter should be installed downstream to protect the injectors from debris.**

Plug in the fuel tank pressure sensor.

Reconnect the battery and turn the key to the ON position. Confirm the new fuel pump(s) prime for a few seconds and check for leaks. If no leaks are found, start the vehicle. The engine may run rough for a few seconds until all the air is bled from the fuel system. Recheck for leaks.

Reinstall the OEM metal cover plate and rear seat.

**Installation Complete**

